



Member of Haitian Die Casting

HDC cold chamber die casting machine series
HDC180T-HDC8800T

宁波保税区海天智胜金属成型设备有限公司

Ningbo Free Trade Zone Haitian Zhisheng Die-Casting Equipment Co., Ltd.

地址:浙江省宁波市北仑港综合保税区灵山路8-1号

ADD: No. 8-1, Ningbo Beilun Integrated Free Trade Zone, Zhejiang, China

邮编 Zipcode: 315806

电话Tel: +86-574-86185710

传真Fax: +86-574-86185710

E-Mail: haitiandc@mail.haitian.com



HT 202.10728-CV



Haitian's 55-year history



1966

◎ President Zhang Jingzhang founded Haitian

1974

◎ Haitian's first injection molding machine

1985

◎ "Haitian" trademark is registered

1994

◎ Haitian's sales volume ranks first in the world

2002

◎ Haitian Precision is established

2005

◎ Haitian Drive is established

2006

◎ Haitian International is successfully listed in Hong Kong (Stock code 01882)

2016

◎ 50th anniversary of Haitian

◎ Haitian Precision is listed in Hong Kong (Stock code 601882)

◎ Haitian Die Casting is officially established

2018

◎ Haitian's new plant in Turkey is opened

◎ Haitian Die Casting wins the "National High-tech Enterprise" certification

◎ Haitian's new plant in India is opened

2019

◎ Haitian Die Casting passes ISO9001

◎ Haitian HDC4500T die casting machine and die casting island are successfully delivered and put into use

2020

◎ Global Application Center of Haitian Die Casting is opened

2021

◎ Haitian Die Casting delivers the first HDC 8800T die casting machine



Haitian Die Casting

Haitian Die Casting is one of the industries of Haitian Group, adhering to philosophy and management concept of Haitian Group, relying on the industrial platform advantages of Haitian Plastics Machinery, Haitian Precision and Haitian Drive and maintaining technical innovation and win-win cooperations to provide customers with complete sets of high-pressure casting equipment and complete solutions with superior cost performance.

In the middle of 2021, new die casting machine production base of Haitian Die Casting in Beilun, Ningbo, with the total investment of \$160 million and an area of 139 acres has been put into operation. It can produce a full series of cold chamber die casting machines with clamping force of 180T-8000T. After the base is fully put into use, it will have an annual production capacity of 4000 die casting machines.

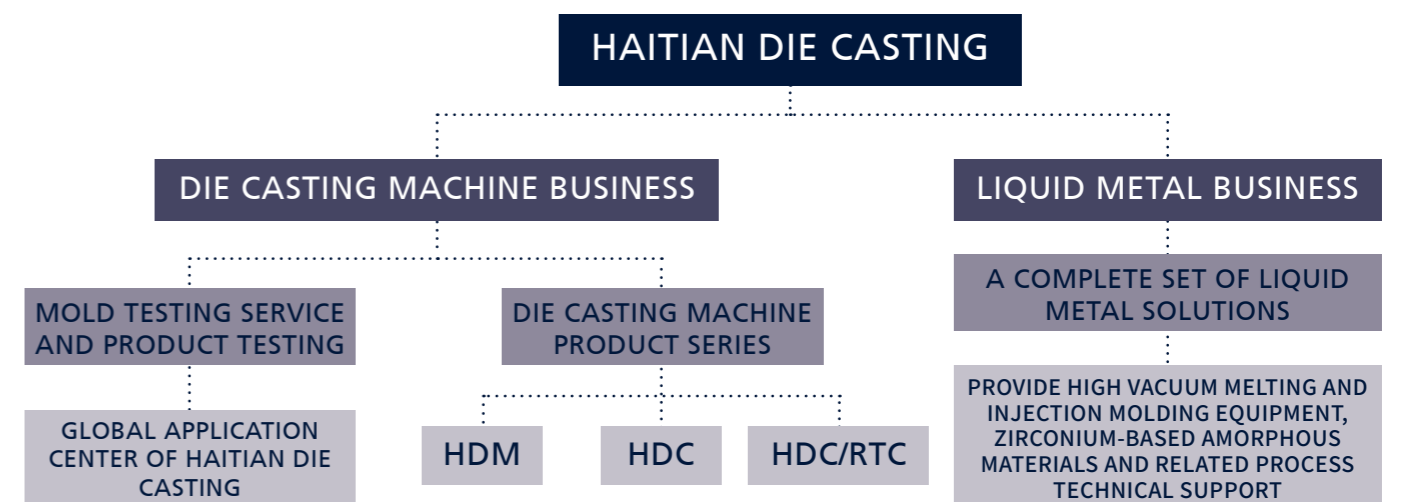

Manufacturing Strength of Haitian Die Casting

More than 50 years of mechanical manufacturing experience

A good machine tool is an important guarantee of product quality. Therefore, Haitian always adheres to the concept that first-class equipment manufactures first-class products and has continuously increased equipment investments. Since 1994, the Company has introduced first-class CNC from advanced countries including Japan, Germany and the United States and has invested in the most advanced flexible processing production line in China, providing solid guarantee for high-precision processing and high-efficiency production. Haitian insists that 100% of the important parts are processed by the Precision Import Processing Center. The large-scale import processing centers such as Mitsubishi Heavy Industries, SHW (8-axis linkage), WALDRICH and SKODA are the mainly production centers for producing heavy machine templates. The small- and middle-sized machine templates are mainly processed by the flexible processing production lines of Mauser and Niigata, the elbows are processed by Cincinnati Machine and FADAC, the frame is processed by the large gantry pentahedron

of Mitsubishi and Haitian Precision and the valve plate is processed by the flexible processing production system of Niigata and Okuma. After installing the workpiece to be processed, all the operation processing process can be completed automatically, completely changing the original processing method of tedious and human error in the operation. For precision parts such as pull rod and piston rod, the Company has introduced dozens of CNC turning centers of Dairijin to form a large-scale CNC turning processing group. The production of appearance sheet metal parts are mainly processed by WIEDMANN and OMADA bending machine, electronic punch, angle cutter and other equipment to ensure the production accuracy. In order to fully guarantee the quality of mechanical parts, the Company has introduced dozens of heat treatment lines from Japan, including well-type nitriding furnaces and nitriding treatments for self-monitoring, which effectively guarantees the heat treatment effect.



Product Application of Haitian Die Casting

Provide customers with efficient die casting solutions

Die casting is an advanced and efficient precision forming technology for nonferrous alloys, capable of producing castings with various complex geometries, which is widely used in various industries for the manufacture of equipment and product parts. Die casting machinery is an important equipment for the development of die casting industry.

Benefiting from the replacement demand for lightweight automobile parts and the growth in demand for parts in line with technological development of industries such as communications and 3C, the die casting machinery industry has a broad development space. In fact, the application fields of die casting is extremely wide, and its products are involved in all aspects of our lives.



SOLUTION FOR AUTOMOBILE STRUCTURAL PARTS



SOLUTION FOR MOBILE PHONE STRUCTURAL PARTS

SOLUTION FOR 5G COMMUNICATION



SOLUTION FOR 3C PRODUCTS



SOLUTION FOR ELECTRIC VEHICLE



SOLUTION FOR SMALL HOUSEHOLD APPLIANCES

For more customized solution, please contact us.

Global Application Center of Haitian Die Casting One-stop Die Casting Solution

With the development of the market application of aluminum magnesium alloy die casting, especially in industries such as the automotive lightweight structural parts, new energy vehicle battery pack and 5G communication, there are more and more highly integrated large-size products and high-demand die castings, and the market demand for ultra-large and ultra-precision die casting machines is also increasing. Therefore, Haitian Die Casting has established a global application center, covering an area of 5000 square meters and equipped with HDM2500T and HDC3500T double closed-loop real-time control die casting machines, aluminum alloy quantitative furnace,

high vacuum equipment, full mold temperature detection and control systems, robot peripheral automation, high-end spray systems, "material laboratory" and "X light detection room", to provide product testing and functionality testing, conduct application testing on new materials, new processes and new technology for global high-end customers and mold factories. Meanwhile, Haitian Die Casting will build a high-end application team to provide customers with a series of application support services from equipment selection, a full set of molding solutions, mold guidance, die casting process and production guidance.



Cloud system (optional)

Intelligent factory solution for die casting enterprises

The customizable cloud system of Haitian Die-Casting is a set of production information management systems for workshops of manufacturing enterprises. It can provide enterprises with functional modules including manufacturing data management, planning and scheduling management, production scheduling management, personnel call management, quality management, equipment life management, tooling management, maintenance management, project display management, production process control, data integration and analysis, etc. It provides decision support for enterprise management and creates a digital intelligent manufacturing collaborative management platform for enterprises.

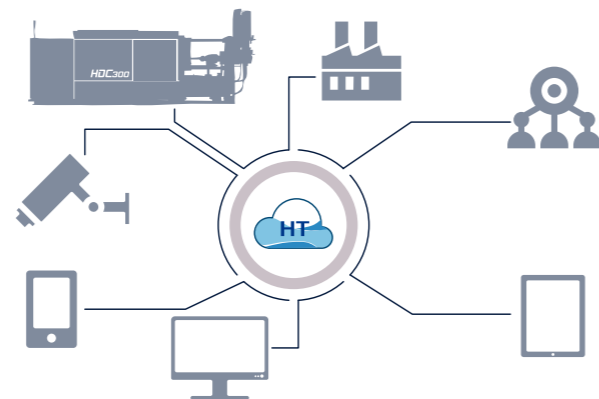

Dual closed-loop full real-time control injection system (optional)

HDC cold chamber die casting machine series

Siemens control system is used for the new generation of dual closed-loop full real-time control injection system developed by Haitian Die Casting to realize closed-loop control of pressing pressure and injection speed and closed-loop control of boost pressure and pressure build-up time. The boost pressure can be set in six sections, realizing high-quality and high-stability perfect injection process, providing perfect equipment guarantee for producing high-precision and high-quality die-casting parts.

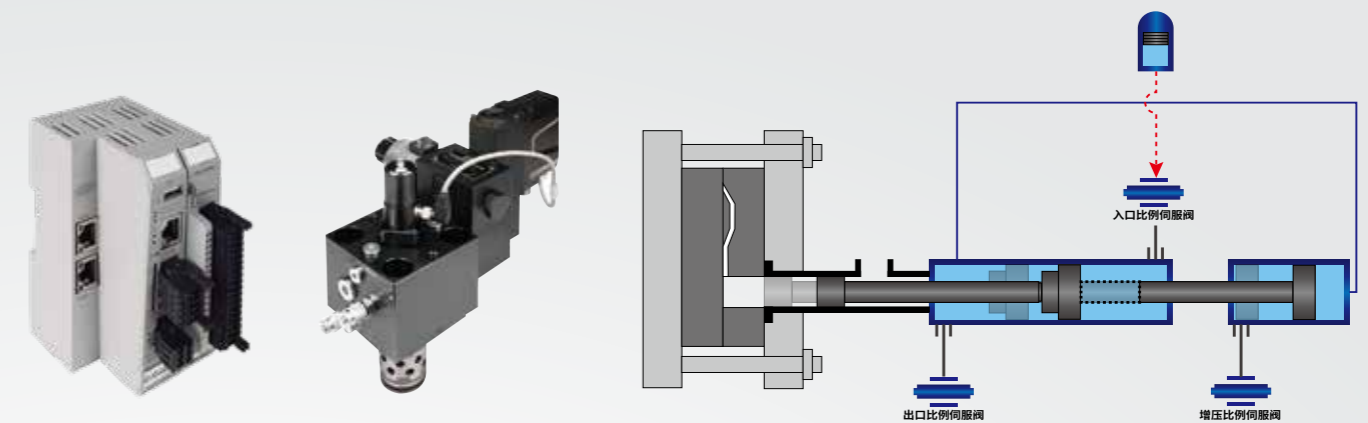

Performance of dual closed-loop full real-time control injection system

- 0.25ms real-time control cycle
- With uniform acceleration function
- Configurable ten-stage injection speed, six-stage intensification pressure, wider process adjustment range
- ± 1 bar intensification pressure real-time control and intensification pressure repeat accuracy
- 0.05m/s-8m/s stepless adjustment for Injection speed, superior acceleration with ultra-low speed extrusion function
- ≤ 20 ms Closed loop control of pressure with very short build-up time
- Excellent high speed repetition accuracy and slow speed repetition accuracy
- With end brake to realize the injection without flash
- Start without impact



HDC cold chamber die casting machine

180T-850T



◎ Dual closed-loop real-time control injection system (optional)

Equipped with fast inlet servo valve + fast outlet servo valve + booster outlet servo valve to realize double closed-loop control of pressure and speed.



◎ Semi closed-loop injection system (optional)

Equipped with electric control valve + injection curve to realize the automatic adjustment of speed I, speed II and boost speed, and automatic correction; at the same time, it can display the pressure, speed, position and other curves, and record the injection data.



◎ Customized second fast valve

The fast response valve specially developed for the speed II acceleration performance of the die casting machine has faster, more stable and more durable injection speed.



◎ Thickened enterprise board

The thickened enterprise board and the thick pull rod are conducive to maintaining the coaxial degree of injection for a long time.



◎ Automatic pressure relief of accumulator

Equipped with quick/boost accumulator unloading valve, it can realize automatic pressure relief of shutdown accumulator with high safety.



◎ Active oil temperature cooling

Active cooling with an independent cooling pump drawing oil from the oil tank to circulate cooling, making the cooling more reliable. (servo)

◎ High performance servo system

Adopting Haitian high performance servo system with remarkable energy saving and configured with efficient and stable oil cooling method. (servo)



◎ Intelligent Keba computer control system

Equipped with the mold locking force display (servo), injection curve and intelligent quality online function of the whole machine, it has a 12 Inch Touch screen with powerful function, stable performance, good expansibility and long service life.



◎ Two-in-one independent electric box

The main control electric box and servo electric box are combined into one, realizing the integral hoisting. After installation, it is separated from the frame without vibration interference.



HDC cold chamber die casting machine

180T-850T



◎ Special tie bar

The tie bar is made of special materials developed by the Haitian Materials Research Institute, with an enlarged diameter, good stress and strong rigidity. After years of practical use, it can significantly extend the service life of the pull rod.



◎ High-performance lock shaft

The lock shaft is made of 38CrMoAl material and is nitridated, with a large diameter, high strength, good toughness and long service life.

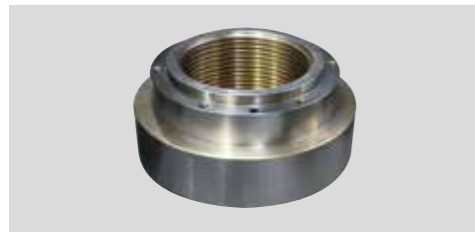

◎ Adjustment nut

The adjustment nut is made of inner pouring aluminum bronze, which has higher mechanical properties, wear resistance, corrosion resistance, cold resistance, heat resistance and no ferromagnetism; it has good antifriction, good elongation and long service life; it can ensure smooth mold adjustment, effectively prevent mold adjustment from not moving, and protect pull rod thread.

◎ Thickened three platens

Thickened three platens have high strength, good wear resistance and small deformation.



◎ Stiffener structure of middle plate

The structure of supporting rib plate is added to the middle plate, which effectively reduces the deformation of the middle plate, and fixes the ejector cylinder on the rib plate, which solves the problems of ejector cylinder swing, uneven ejector force, broken ejector pin, broken ejector cylinder piston rod, etc.



◎ Machine body design

The machine body is of high-strength I-beam structure. The centerline of the sliding foot of the template and the center line of the upper and lower tie bars are in the same plane with the I-beam support bar. After annealing treatment, the anti-twisting ability and rigidity of the frame are greatly enhanced, which ensures the overall accuracy of the machine for a long time.

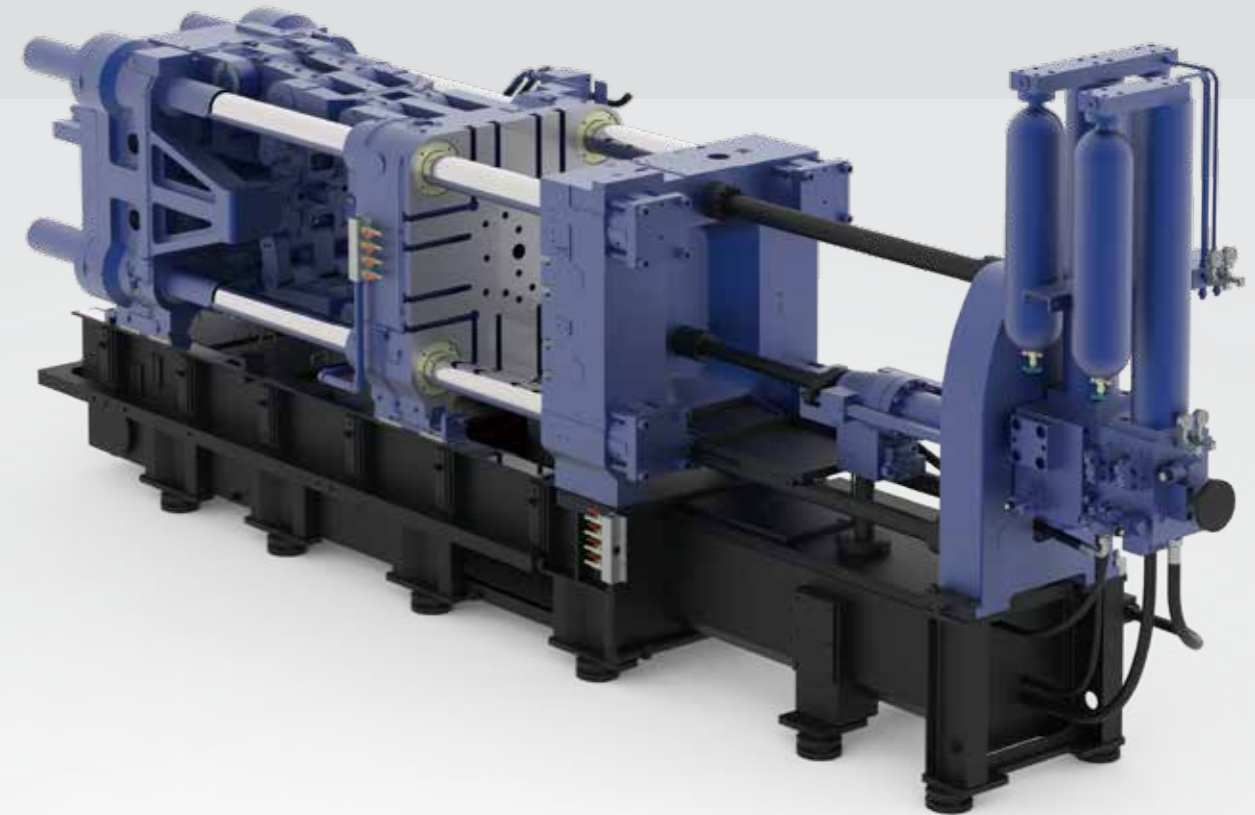
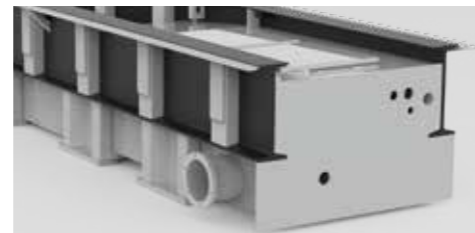

◎ Mold closing motion analysis

Through the analysis of Haitian's unique hinge motion software, the five-point mechanical structure is optimized and advanced slope control mode is adopted to make the energy output curve of the pump station system, the motion curve of the mold locking cylinder and the motion curve of the mechanical hinge be almost perfectly matched; within the range of the mold opening stroke, the middle plate can stop at any position within the opening stroke and with high repetition accuracy, effectively shortening the production cycle.

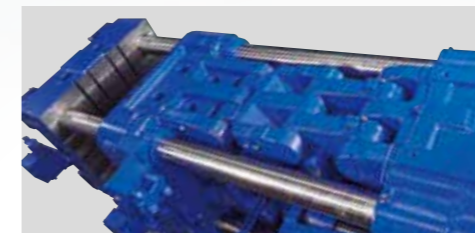

◎ Intelligent mold adjustment structure

Equipped with automatic mold adjustment function, the hinge can be extended to adjust the mold. The mold adjustment motor is equipped with a self-locking function, which effectively solves the problem of the reduction of the clamping force caused by the retreat of the mold closing mechanism, and better guarantees the stability of the product.



◎ Extended guide sleeve structure

The extended guide sleeve structure of middle plate can ensure more smooth and reliable operation of middle plate.



HDC cold chamber die casting machine

1000T-4500T



◎ Double closed-loop full real-time control system

Equipped with fast inlet servo valve + fast outlet servo valve + booster outlet servo valve to realize fast double closed loop control of pressure.



◎ High system pressure

The pressure of the system can reach 190bar-210bar, the reaction speed of the whole machine is faster and the performance is better.

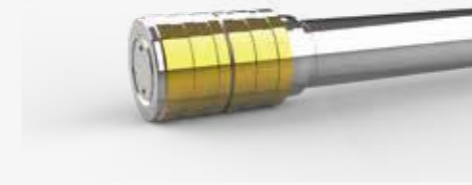

◎ Large material cylinder piston

The exclusive rigid welding structure can reduce the friction resistance in the process of movement, reduce energy loss, effectively avoid the internal leakage caused by the pulling of the injection cylinder and prolong the service life of the seal.



◎ Multiple hydraulic oil filtration

Equipped with oil suction filter, outlet high-pressure filter, bypass filter, core-pulling oil return filter, injection servo filter, etc., it can greatly improve the protection of hydraulic oil cleanliness and ensure the reliable work and service life of hydraulic components.



◎ Detection and control of hydraulic oil

Equipped with multiple oil temperature and oil level display and alarm, and equipped with automatic oil temperature preheating function and independent pump active water cooling system, oil temperature control is more reliable.

◎ Design of independent oil tank

The independent oil tank structure and paint baking process are more favorable to the hydraulic system, and the oil change and maintenance are more convenient.



◎ Substation mode

The industry's first to use the mode of substation mode (IO distributed), which is more stable and anti-interference; multiple CPU partitions are independently controlled and the circuit is simplified, making the signal transmission faster.



◎ High performance servo system

Adopting Haitian high performance servo system with remarkable energy saving and configured with efficient and stable oil cooling method.



HDC cold chamber die casting machine

1000T-4500T



◎ Upgraded tie bar material

CL516, which is newly developed by Haitian Materials Research Institute, has higher strength and better toughness.



◎ Auxiliary template

The mold surface of the movable and fixed plate is equipped with P20 mold steel (auxiliary template), which completely solves the long-term problem of mold surface depression in the industry, and also improves the rigidity of the template.



◎ Hydraulic pulling rod

Hydraulic pulling rod is above the operation side; the installation position of the hydraulic pulling rod above the non-operation side is reserved for self-selection.

◎ Over stress protection mechanism

The special over stress protection mechanism is adopted for the head plate tie bar nut, which can effectively protect the pull rod and significantly prolong the service life in case of unbalanced force on the mold.



◎ Mold opening and closing control

The large flow proportional valve is used to control mold opening and closing, making the mold opening and closing reaction faster and the position more accurate. At the same time, the clamping hydraulic safety valve is configured, making the clamping safety protection more reliable.



◎ Ejector mechanism

The ejector position is controlled by MTS magnetic scale + travel switch, which is a dual configuration for easy switching.



◎ High-strength body

Exclusive use of I-beam or H-beam structure frame, and the overall annealing stress relief, good force, rigidity, good resistance to deformation.



◎ Multiple security facilities

Equipped with safety module, front door safety grating, rear door electric eye, life safety lock, mold locking confirmation, machine hinge grating protection and multiple emergency stop switches, making operation safety more secure.



Technical parameters

180T-1000T

		HDC180	HDC350	HDC450	HDC550	HDC700	HDC850	HDC1000
Clamping force	kN	1800	3500	4500	5500	7000	8500	10000
Clamping stroke	mm	380	460	550	580	670	760	880
Ejection force	kN	125	180	200	250	360	360	500
Ejection stroke	mm	85	110	130	150	160	180	200
Mold thickness (min-max)	mm	250-600	250-700	300-750	350-850	350-900	400-950	450-1150
Platen Size (Horizontal x Vertical)	mm	710×710	910×910	1050×1050	1200×1200	1380×1380	1470×1470	1680×1680
Tie Bar Spacing (Horizontal x Vertical)	mm	460×460	570×570	650×650	755×755	860×860	930×930	1030×1030
Tie Bar Diameter	mm	∅ 90	∅ 120	∅ 140	∅ 150	∅ 180	∅ 190	∅ 200
Injection Force (Intensified)	kN	300	380	476	580	605	695	885
Injection stroke	mm	350	410	510	600	650	760	800
Plunger Tip Diameter	mm	40/50/60	50/60/70	60/70/80	70/80/90	70/80/90	80/90/100	90-120
Injection volume (aluminum)	kg	0.8/1.3/1.9	1.5/2.2/3.0	2.7/3.7/4.8	4.3/5.7/7.2	4.7/6.1/7.7	7.2/9.1/11.2	9.5-17
Casting Pressure (Intensified)	MPa	239/153/106	194/135/99	168/124/95	151/115/92	157/120/95	138/109/89	139-78
Casting area	cm ²	75/117/170	194/135/99	268/363/474	364/478/601	446/583/737	616/780/955	719-1278
Maximum casting area (40MP)	cm ²	450	875	1125	1375	1750	2125	2500
Injection position	mm	-140	-125/-140	-175	-175	-250	0,-250	0,-300
Plunger Tip Protrusion	mm	135	152	210	270	280	300	300
Shot Sleeve Flange Diameter	mm	101.6	101.6	101.6	165	165	200	240
Shot Sleeve Flange Protrusion From Fixed Platen	mm	12	12	12	15	15	20	20
System working pressure	MPa	16	16	16	16	16	16	19
Motor power/servo motor power	kW	15/18.5	22/31.4	30/42.5	37/53	63.5	63.5	60.5
Hydraulic Oil Filling Volume	L	400	660	750	950	1100	1200	1900
Lifting reference weight	T	6.8	11.6	16.4	21.9	32.3	37.1	60
Overall dimension (L × W × H)	mm	5950×1650×2700	6210×1750×2700	7200×1950×2780	8300×2090×2890	9025×2270×2900	9560×2450×3230	10100×3570×3100

The Company reserves the right to modify the technical parameters without prior notice.

Technical parameters

1300T-4500T

		HDC1300	HDC1650	HDC2000	HDC2500	HDC3000	HDC3500	HDC4000	HDC4500
Clamping force	kN	13000	16500	20000	25000	30000	35000	40000	45000
Clamping stroke	mm	1000	1200	1400	1500	1550	1600	1800	1900
Ejection force	kN	560	570	650	750	900	900	1000	1000
Ejection stroke	mm	210	250	300	300	300	300	350	400
Mold thickness (min-max)	mm	450-1200	500-1400	600-1600	750-1800	800-2000	800-2000	900-2100	900-2200
Platen Size (Horizontal x Vertical)	mm	1800×1800	2090×2090	2350×2250	2500×2500	2650×2650	2800×2700	2960×2900	3100×3000
Tie Bar Spacing (Horizontal x Vertical)	mm	1100×1100	1250×1250	1450×1350	1600×1500	1650×1650	1750×1650	1850×1850	1965×1865
Tie Bar Diameter	mm	Ø 240	Ø 260	Ø 290	Ø 320	Ø 340	Ø 350	Ø 390	Ø 410
Injection Force (Intensified)	kN	1125	1295	1700	1700	2110	2410	2500	2500
Injection stroke	mm	910	970	1050	1100	1250	1400	1600	1600
Plunger Tip Diameter	mm	100-140	110-150	130-170	140-180	150-190	160-200	160-200	180-220
Injection volume (aluminum)	kg	13.4-26.3	17.3-32.1	26.1-44.7	31.7-52.5	41.4-66.4	52.8-82.5	60.3-94.2	76.3-114
Casting Pressure (Intensified)	MPa	143-73	136-73	128-75	110-67	119-74	120-77	124-80	98-66
Casting area	cm ²	910-1780	1210-2260	1562-2670	2270-3730	2510-4030	2915-4545	3217-5027	4580-6842
Maximum casting area (40MP)	cm ²	3250	4125	5000	6250	7500	8750	10000	11250
Injection position	mm	-160,-320	-175,-350	-175,-350	-200,-400	-250,-450	-300,-600	-300,-600	-300,-600
Plunger Tip Protrusion	mm	355	400	450	450	550	600	745	700
Shot Sleeve Flange Diameter	mm	240	260	260	280	280	320	320	340
Shot Sleeve Flange Protrusion From Fixed Platen	mm	25	25	30	30	30	35	35	35
System working pressure	MPa	19	19	19	19	21	19	21	21
Motor power/servo motor power	kW	62.5×2	62.5×2	69.5×2+57	69.5×2+57	62.5×3	69.5×2+57×2	62.5×4	62.5×4
Hydraulic Oil Filling Volume	L	1900	2100	2950	3050	3100	3300	3400	3400
Lifting reference weight	T	80	105	130	160	180	210	280	300
Overall dimension (L × W × H)	mm	11150×4470×4020	12000×4600×4650	13000×4800×4800	14000×5100×5100	15300×5300×5200	15800×5400×5300	16500×5450×5390	17000×5600×5400

The Company reserves the right to modify the technical parameters without prior notice.

Note: if an independent core-pulling pumping station is selected, the injection volume of hydraulic oil will be increased by 800L.

Template diagram

180T-550T

HDC180

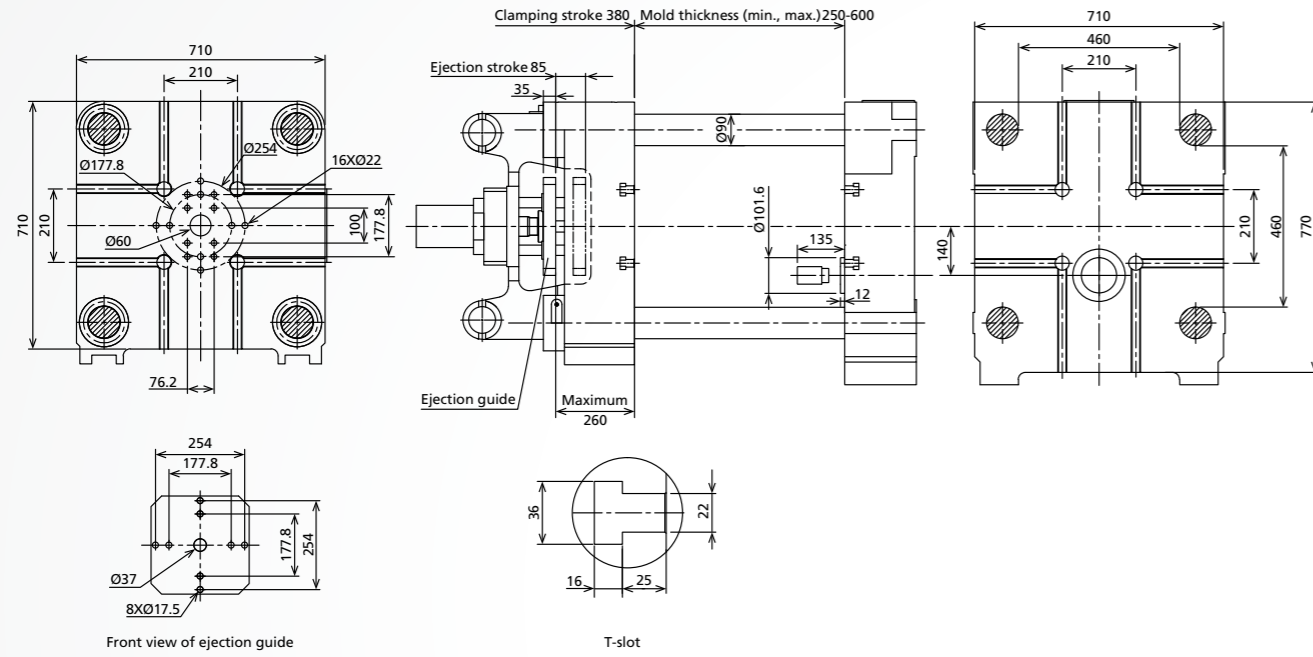

HDC450

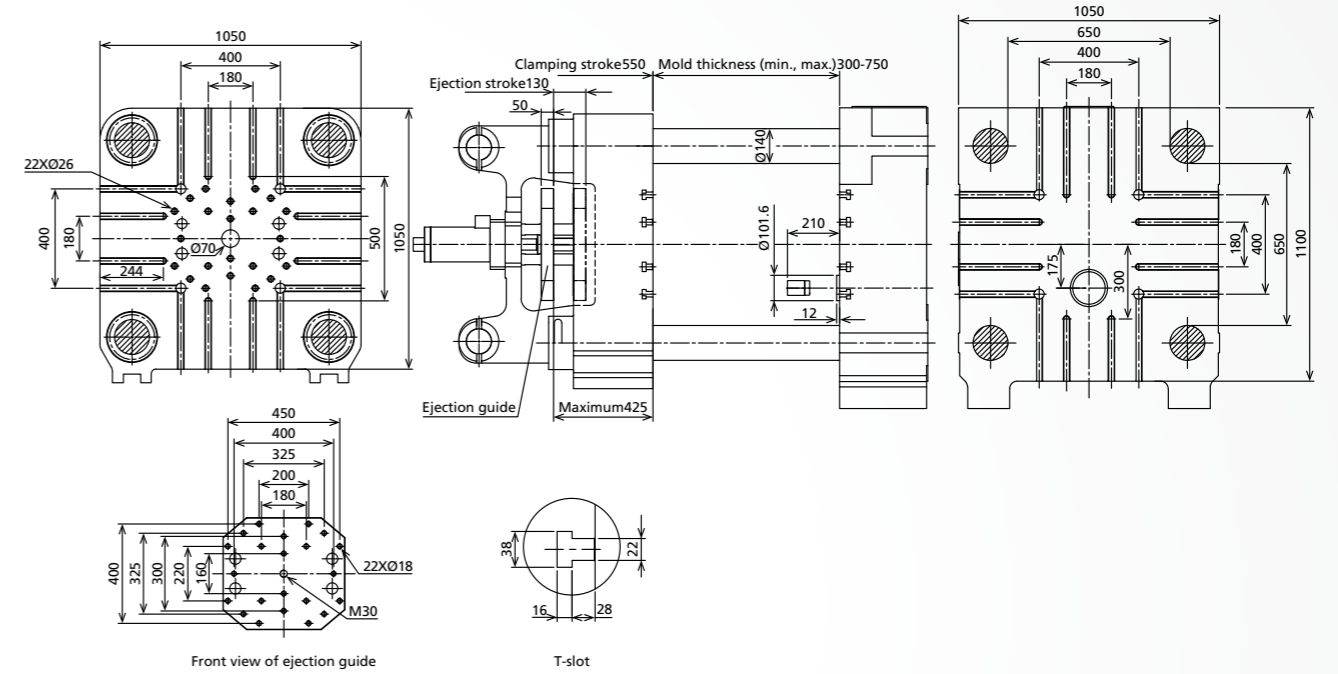

HDC350

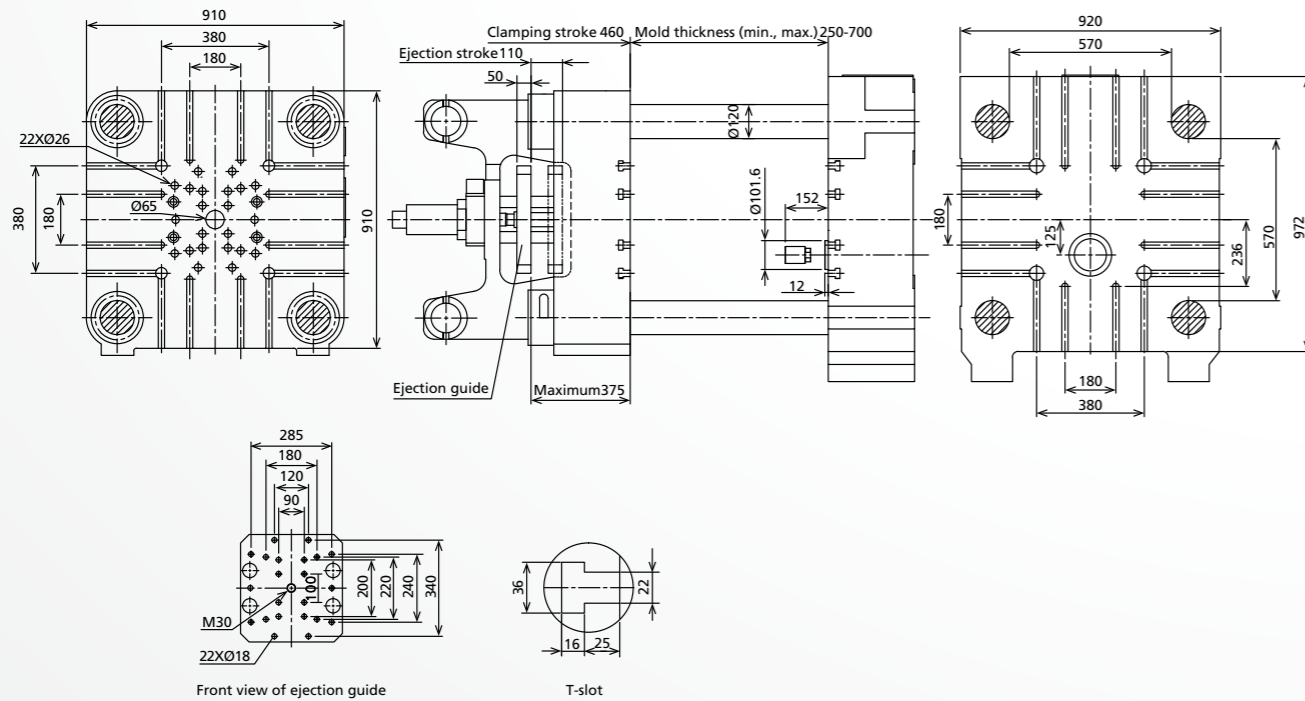

HDC550

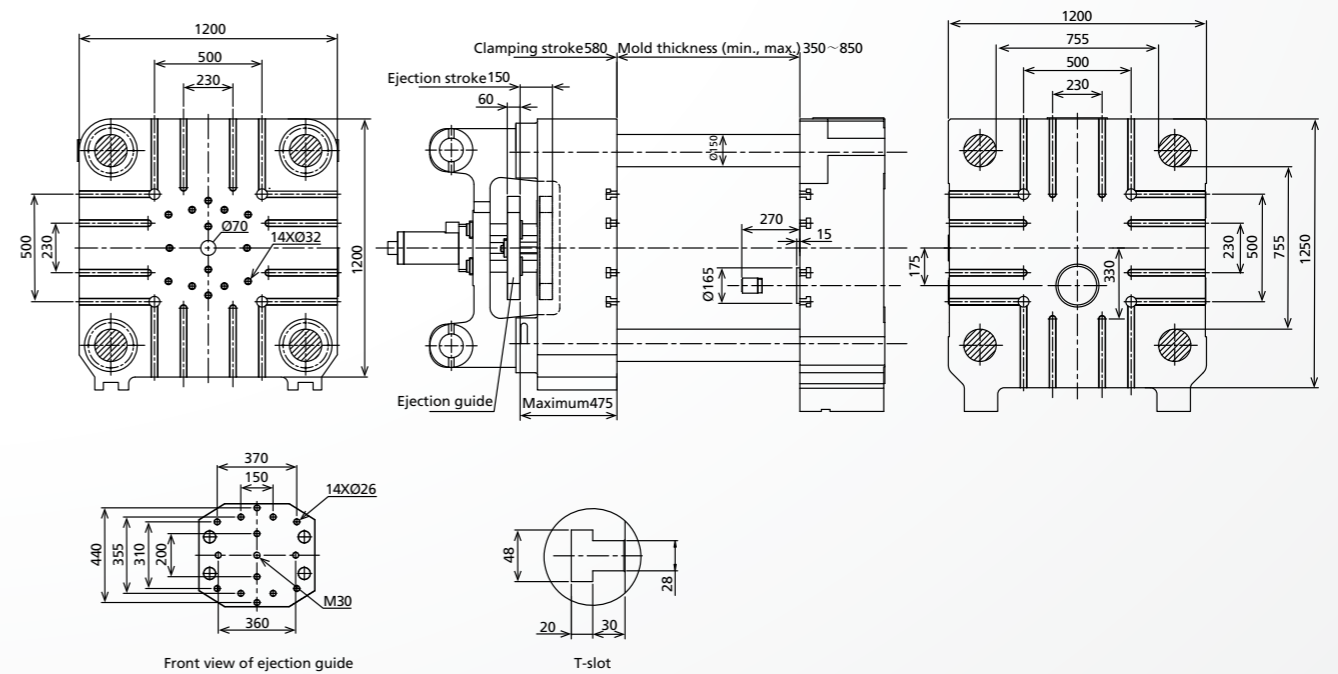

Template diagram

700T-1300T

HDC700

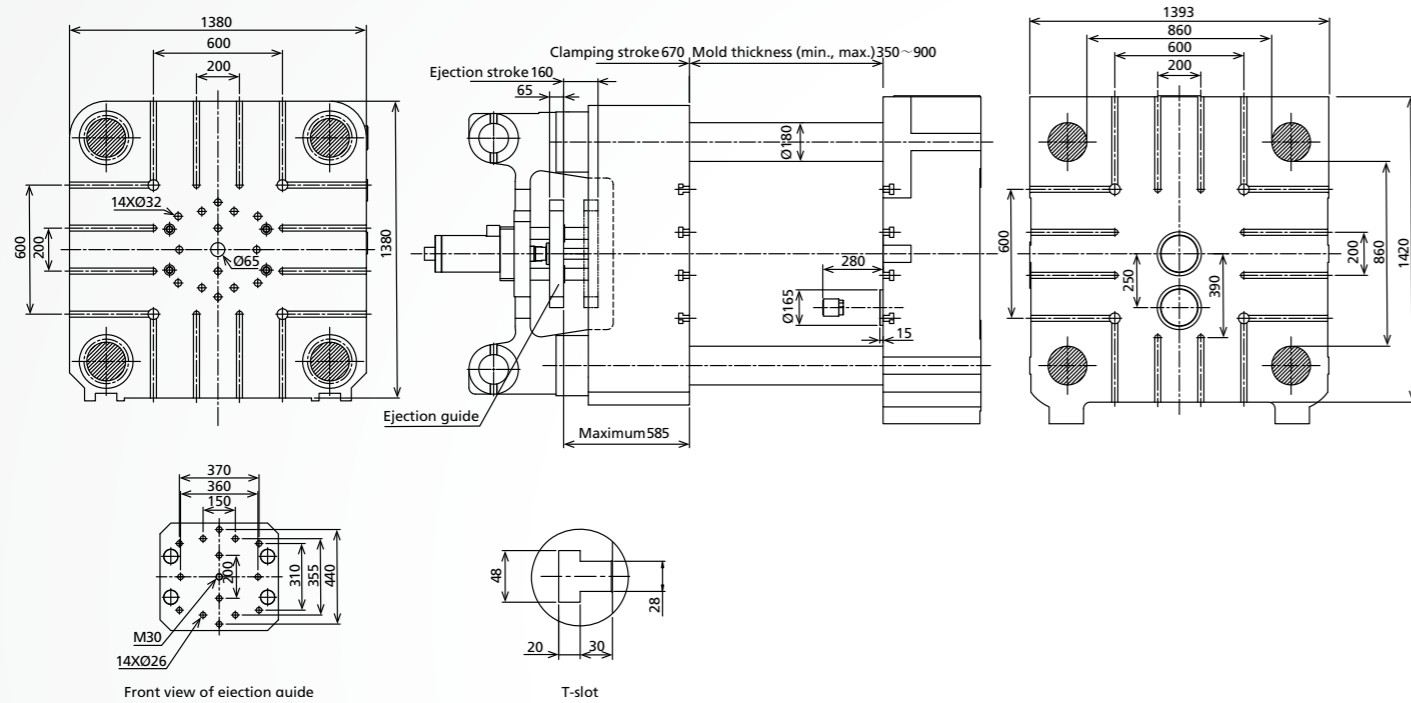

HDC1000

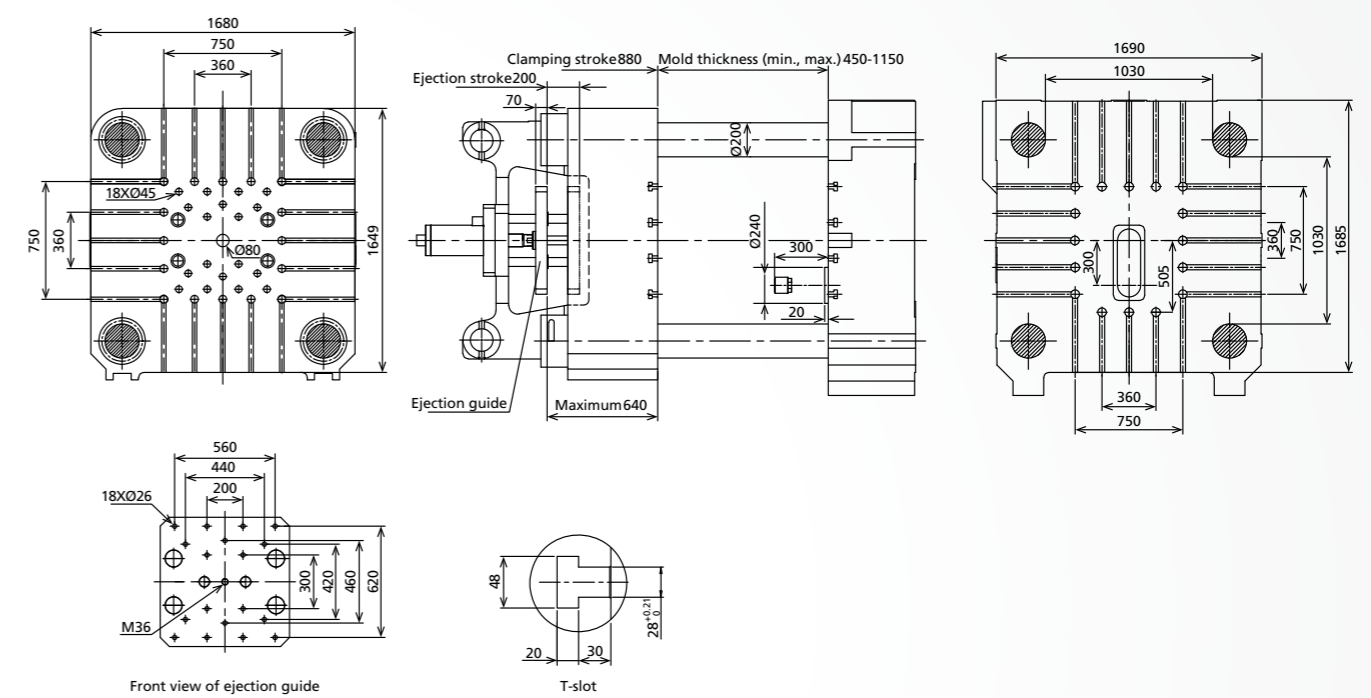

HDC850

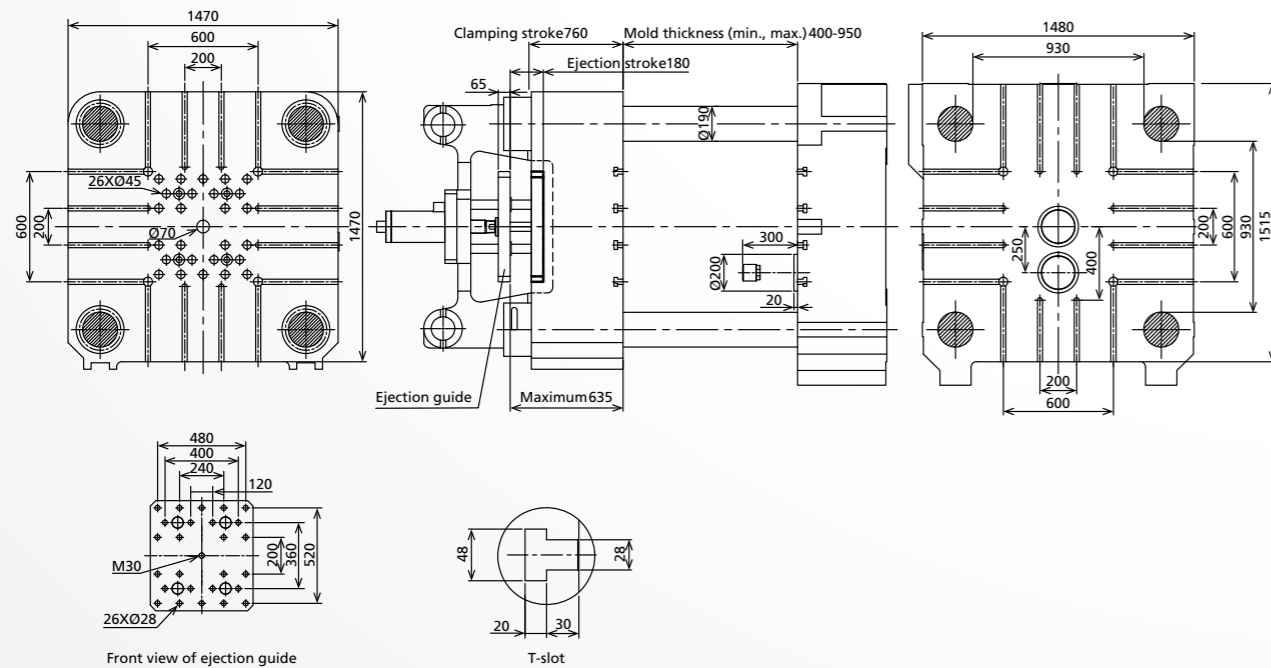

HDC1300

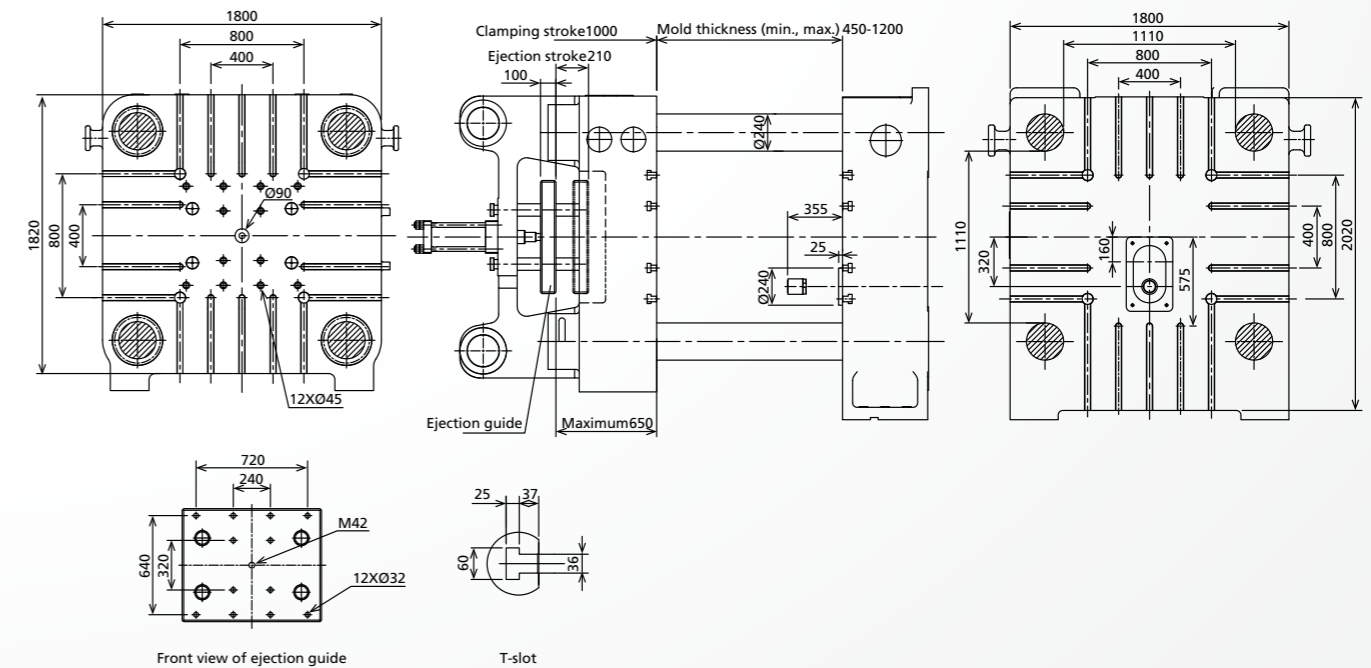

Template diagram 1650T-3000T

HDC1650

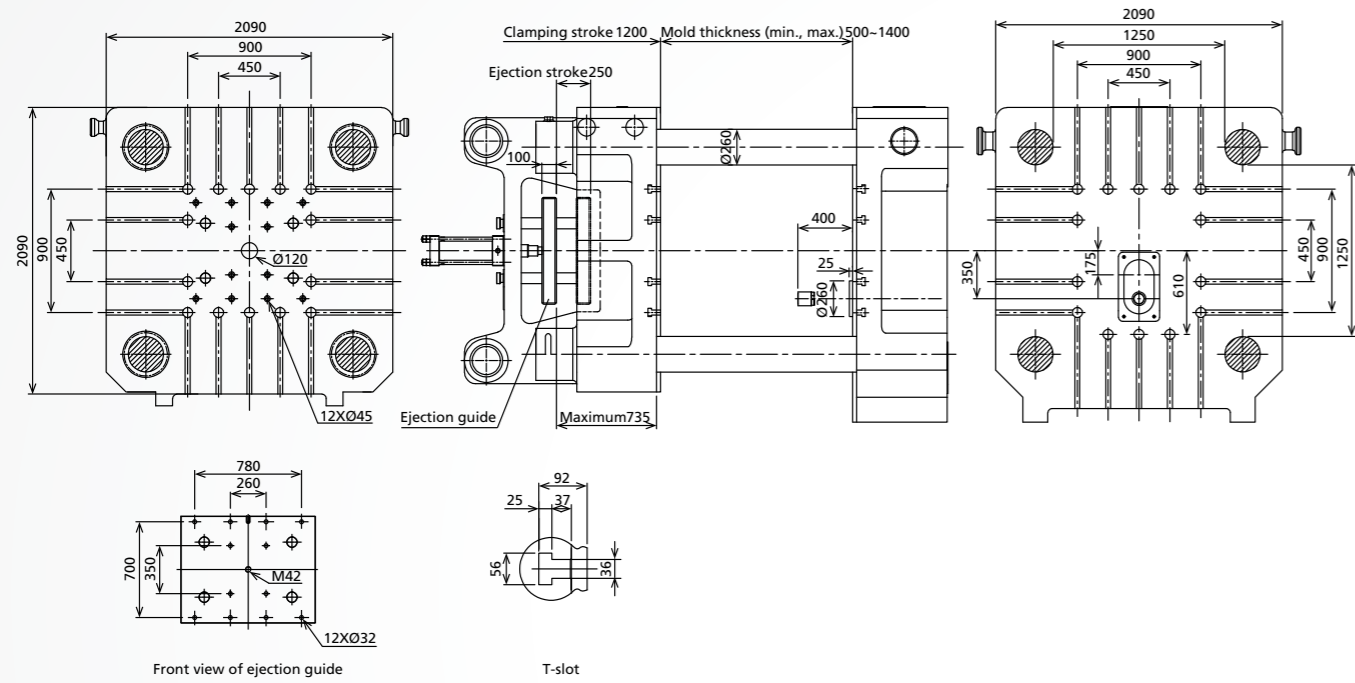

HDC2500

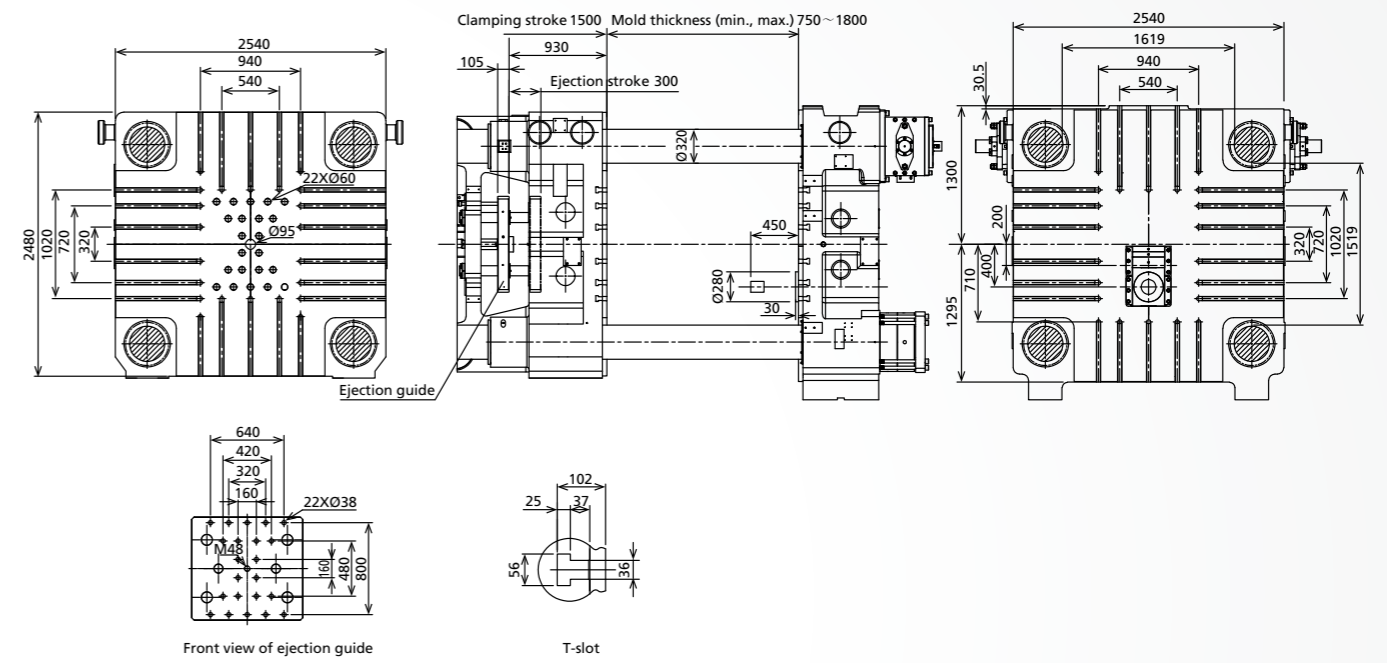

HDC2000

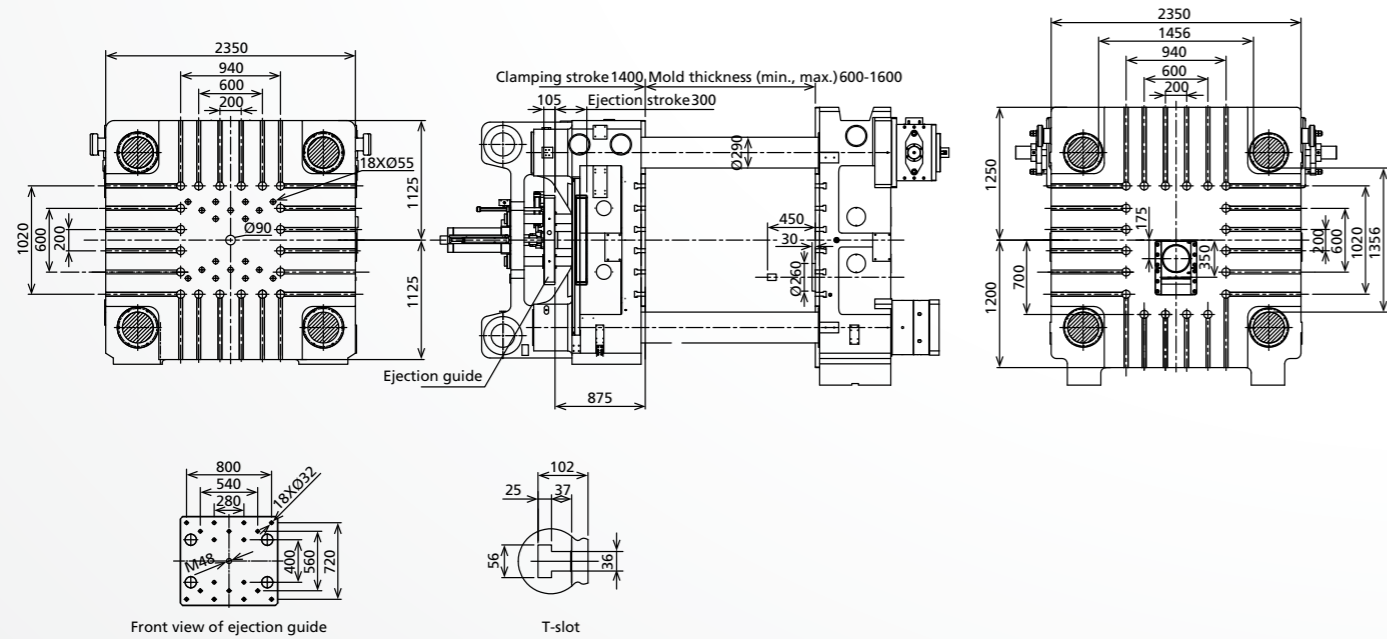

HDC3000

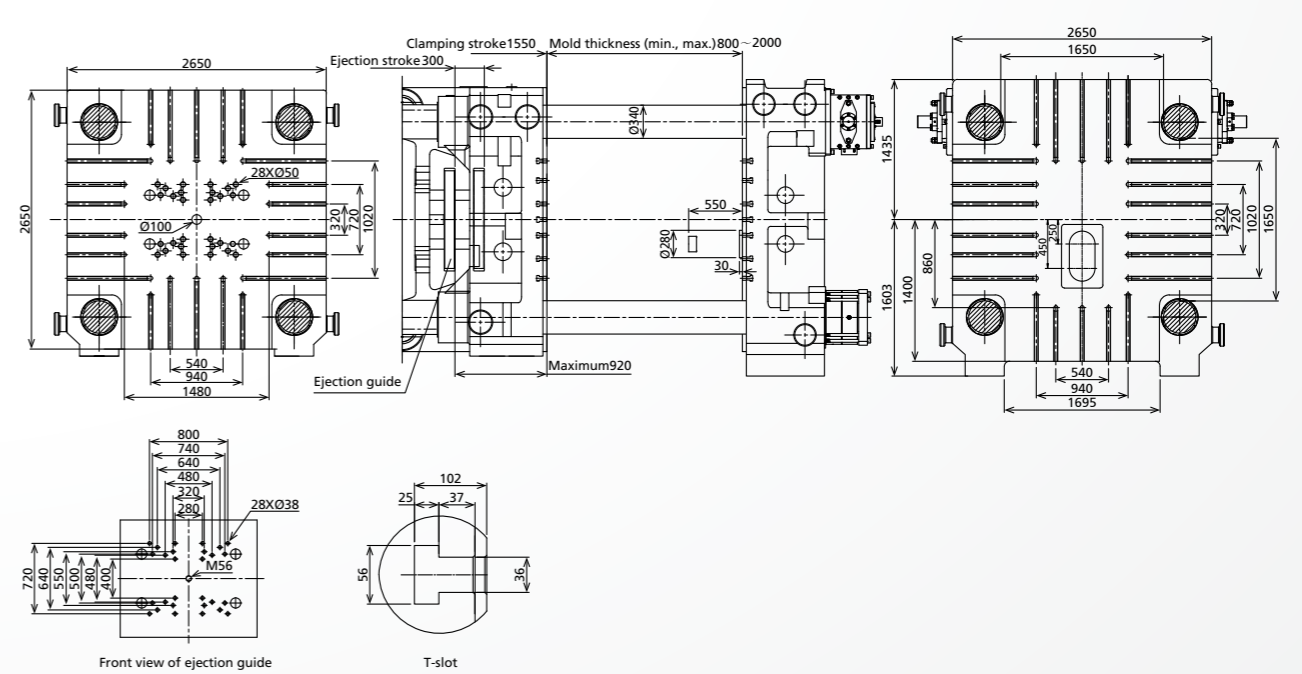

Template diagram 3500T-4500T

HDC3500

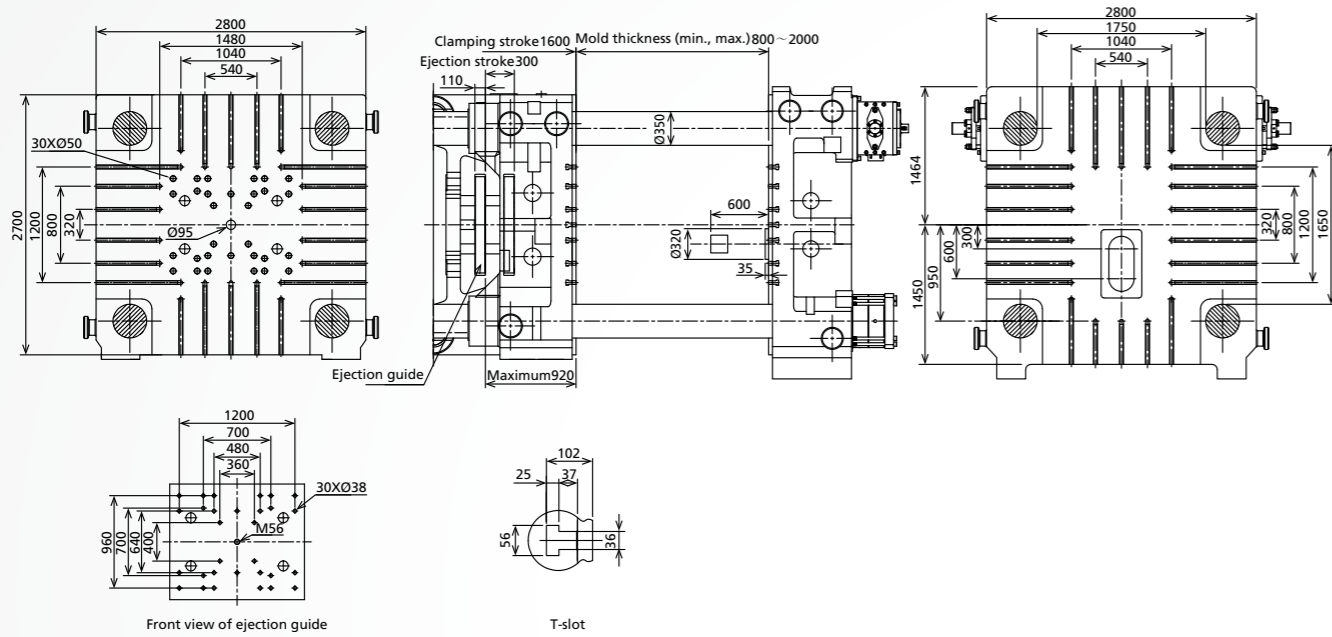

HDC4500

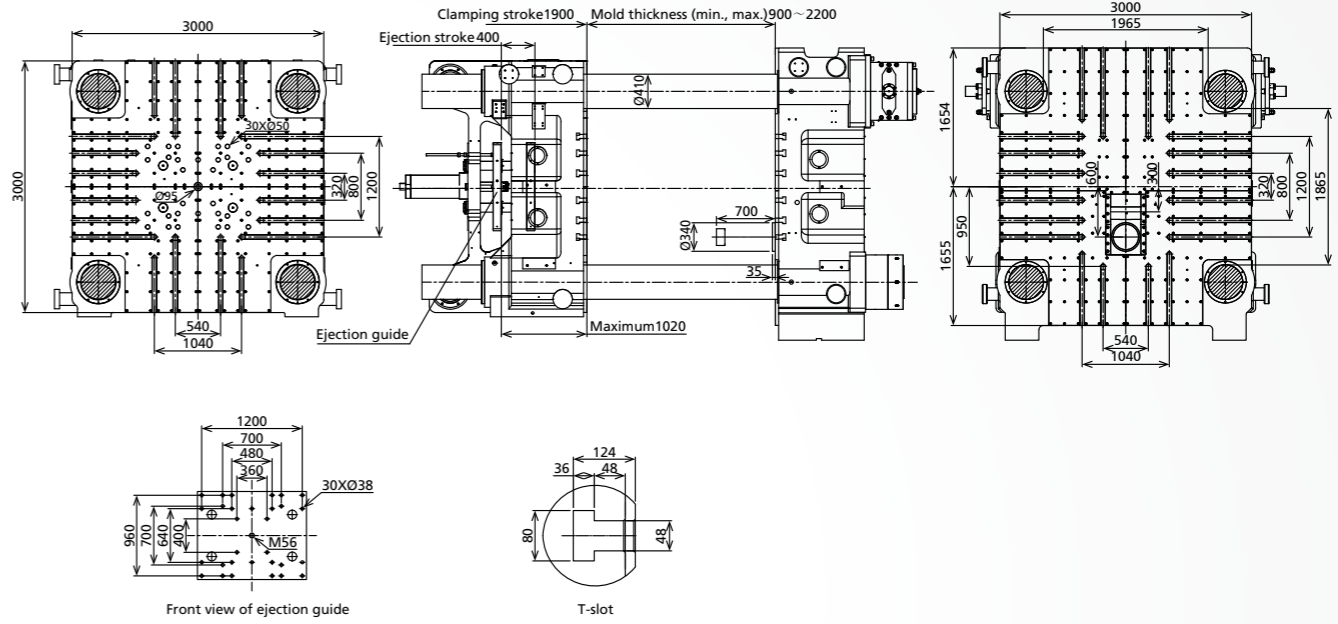

Remarks: please consult the manufacturer for 5,000T - 8,800T

HDC4000

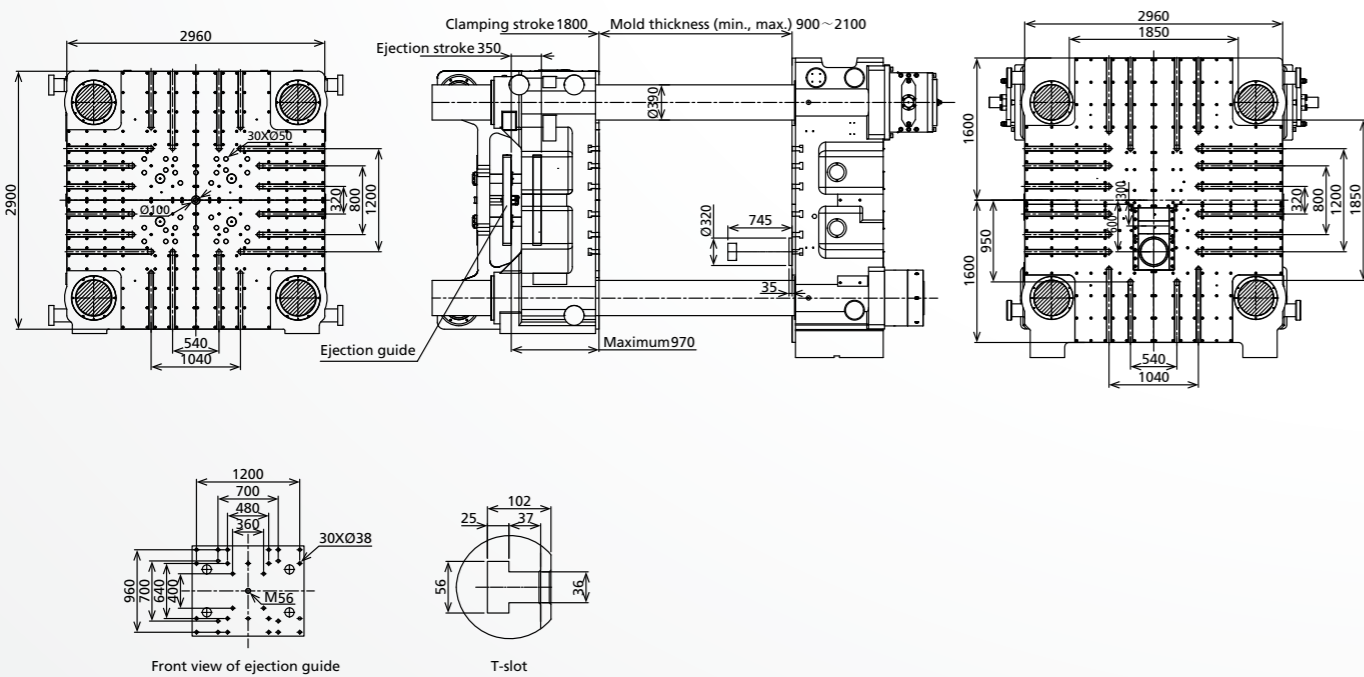

Top view of equipment

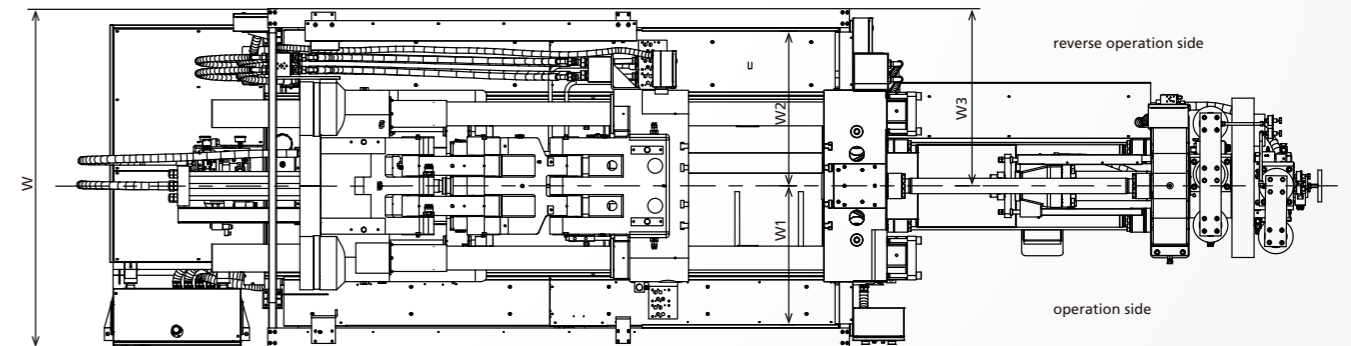

Distance between front and rear safety doors

Model	HDC180	HDC350	HDC450	HDC550	HDC700	HDC850
RTC injection system	○	○	○/●	○/●	○/●	○/●
Overall width W (mm)	1650	1750	1950/2000	2090/2520	2270/2825	2450/2825
Inner distance W1 of safety door on operation side (mm)	740	760	870/770	920/1080	1010/1230	1070/1230
Inner distance W2 of safety door on reverse operation side (mm)	760	830	910/900	1000/1080	1090/1230	1210/1230
Maximum distance W3 (mm) of picker	830	880	965/1000	1050/1190	1140/1340	1260/1340

Model	HDC1000	HDC1300	HDC1650	HDC2000	HDC2500	HDC3000	HDC3500	HDC4000	HDC4500
RTC injection system	●	●	●	●	●	●	●	●	●
Overall width W (mm)	3570	4470	4600	4800	5100	5300	5400	5450	5600
Inner distance W1/W2 of safety door(mm)	1650	1700	1850	2180	2270	2330	2400	2480	2500

备注：单侧内平台标准宽度 HDC1000T-1650T 为 800mm, HDC2000T 及以上为 1000mm